

Heavy Duty Multi Coil Electromagnetic Chuck

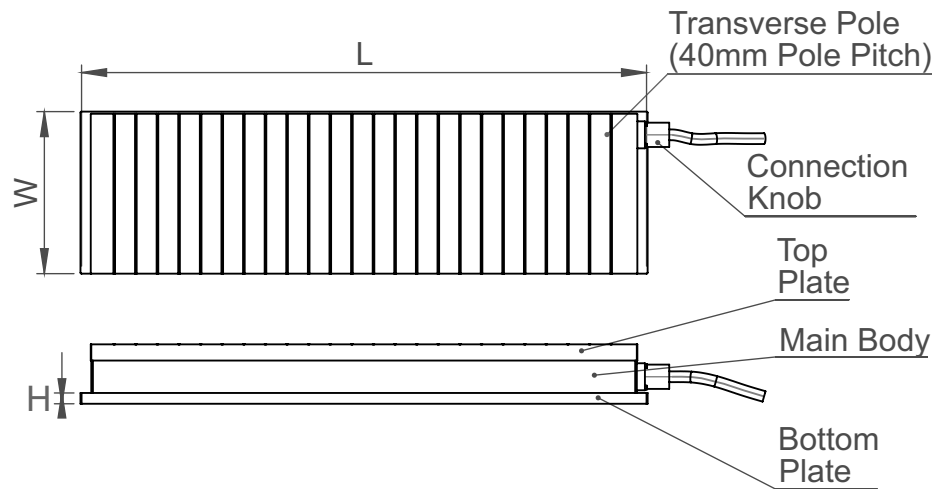

(Accuracy as per IS 8710-1978)



Application

Electromagnetic Chucks are designed for GRINDING operations. It generates strong magnetic force to hold work piece in rigid manner. These chucks are operated on continues D.C. Power Supply. There is no internal wear and deformation corresponding to movement of internal parts, which provides a better life than conventional Permanent Magnetic Chuck.

Characteristics of Electromagnetic Chuck

- Construction:- Fabricated body using High Permeability Steel .
- Separation of pole :- using brass strips
- Conductor:- Copper wire.
- Class of Insulation:- H class
- Winding Base- FRP Former
- Bounding :- Epoxy potting
- It operate on continuously D.C. supply
- Operating Through:- Operating Pendent.

Characteristics of Control Panel

- Input: Powers supply required:- 230 V A.C. supply
- Output: Operating voltage:- 110V D. C. Supply
- Panel safety Precaution:- Using Fuses on AC supply , DC supply and MCB.
- Indication:- Using Indication for main supply, Magnet ON and demag cycle.

Inspection

Following tests are applied to inspect a chuck

- Resistant to Earth Terminal Test
- De-magnetizing Test



Heavy Duty Multi Coil Electromagnetic Chuck

- 3) High Voltage Test
- 4) Leak Proof Test
- 5) Sleeping force Test

Available Sizes

Model Code	Size (L x W x H)	Pole gap	Pole Pitch
002-02-01	450 x 150 x 100 mm	15mm	40mm
002-02-02	500 x 200 x 100 mm	15mm	40mm
002-02-03	600 x 200 x 100 mm	15mm	40mm
002-02-04	600 x 250 x 100 mm	15mm	40mm
002-02-05	750 x 250 x 100 mm	15mm	40mm
002-02-06	900 x 250 x 100 mm	15mm	40mm
002-02-07	600 x 300 x 100 mm	15mm	40mm
002-02-08	750 x 300 x 100 mm	15mm	40mm
002-02-09	900 x 300 x 110 mm	15mm	40mm
002-02-10	1000 x 250 x 110 mm	15mm	40mm
002-02-11	1000 x 300 x 110 mm	15mm	40mm
002-02-12	1500 x 250 x 110 mm	15mm	40mm
002-02-13	1500 x 300 x 110 mm	15mm	40mm
002-02-14	1500 x 400 x 110 mm	15mm	40mm

Applications

