

Online Magnetic Separator For Coolant Oil

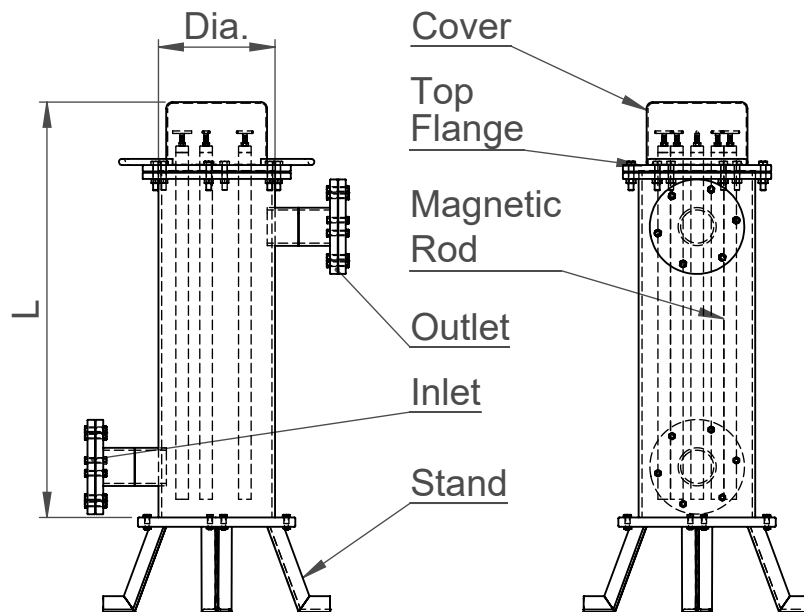

Purpose

Vessel type magnetic separator are used for separating ferrous particles from coolant oil. Particularly these vessels are installed in oil line. The vessel size is bigger than the pipe diameter to maintain rate of flow.

Location

Particularly this separator is installed where the impure oil is arrives from machine for filtration purpose so that it can be filter and pure oil can be supply to machine.

Construction

The body of vessel made by SS304/ Mild Steel. It is available in Nd Fe B grade magnets and Strontium ferrite magnets. Outer tube is made by SS304 /SS316 grade steel (Non magnetic steel).

Maintenance

These magnetic cartridges are required to cleaning periodically for getting good results, the cleaning frequency is decide by the operator.

Advantages:-

- a) Fatigue reduces. (save energy)
- b) Increasing productivity.
- c) Increasing quality.

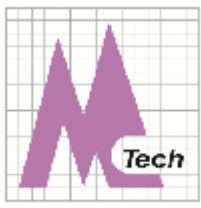

Online Magnetic Separator For Coolant Oil

- d) No Electricity is required.
- e) Absolutely environmentally friendly (No gases chemicals generated)
- f) No maintenance is required.

Area of application:- Chemical industries, Automobile industries etc.

Available Sizes

Model Code No.	Size (L x W x H)
018-06-01	Dia.200 x Length 700mm
018-06-02	Dia.200 x Length 400mm

Applications

