

Motorized Magnetic Separator For Coolant Oil

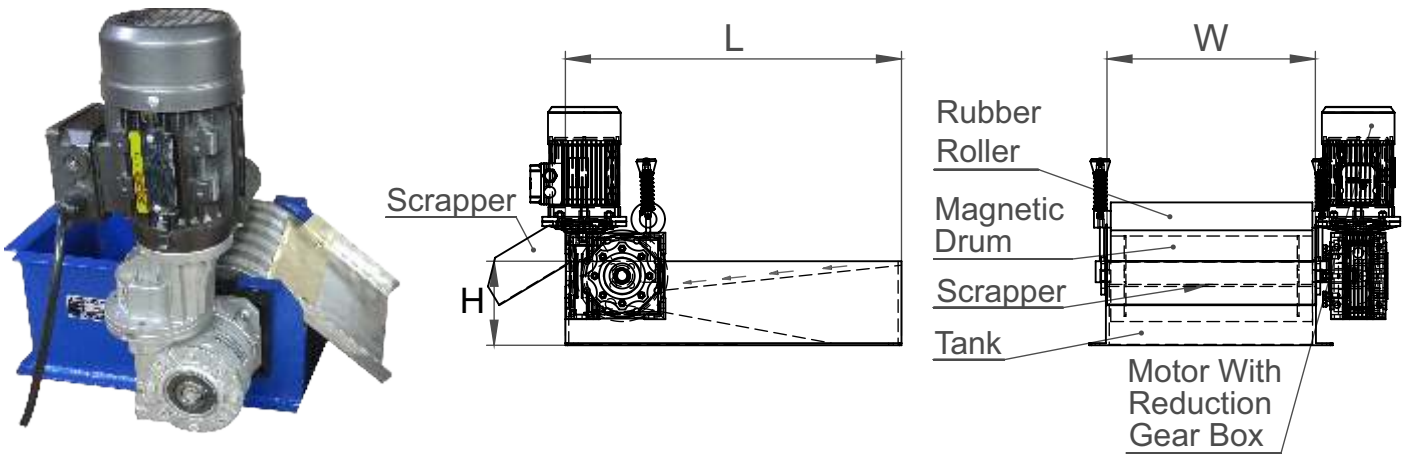

Purpose

This separator is used for separating ferrous particles from coolant oil.

Location

Particularly this separator is installed where the impure oil is arrives from machine for filtration purpose so that it can be filter and pure oil can be supply to machine.

Construction:-

Overall body is made in MS fabrication. It consist Magnetic Drum , Motor with Reduction Gear Box , Scraper, Rubber Roller. The Magnetic drum is consist Nd Fe B grade magnets OR Strontium ferrite magnets. Outer shell of magnetic drum is made by SS304 /SS316 grade steel (Non magnetic steel) or it can be manufacture without outer shell.

Operating Method

Impure oil collect in tanks and coming into the contact with rotating magnetic drum, magnetic drum collect ferrous particles with oil contains on the same time rubber roller squeezing oil contains from drum and ferrous particles remove by scraper so that pure oil collect in main tank fro reutilization.

Advantages:-

- Fatigue reduces. (save energy)
- Increasing productivity.
- Increasing quality.
- Absolutely environmentally friendly (No gases chemicals generated)
- No maintenance is required.



Motorized Magnetic Separator For Coolant Oil

Area of application

Automobile industries- Grinding Machine, Milling Machine, Hobbing machine, Gear Cutting Machine etc.

Available Sizes

Model Code	Size (L x W x H)	Capacity per Minutes
018-07-01	L300 x W200x H 200mm	30 Liter per minute
018-07-02	L600 x W400 x H500mm	60 Liter per minute
018-07-03	L800 x W600 x H300mm	75 Liter per minute