

Parallel Block

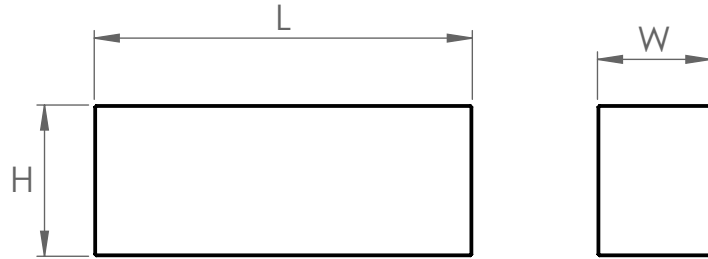
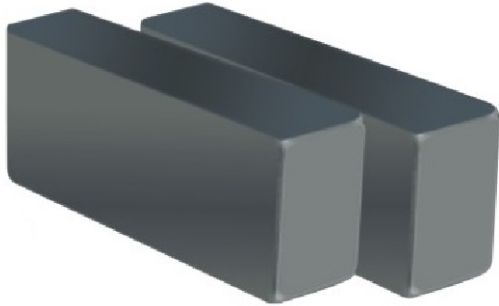

Purpose

Parallel blocks are made by special quality steel it is hardened and ground, the hardness is 55-60R.C. all four sides are chamfered, its precision instrument. Accuracy for flatness, parallelism and squarness within 5 microns.

Construction

It made by alloy steel with case hardening.

Advantages

- Easy for handling.
- Increasing productivity.
- No Electricity is required.
- Absolutely environmentally friendly (No gases chemicals generated)
- No maintenance is required.

Area of application

All tool room/ standard room , Machine shop etc.

Available Sizes

Model Code	Size (L x W H)
028-01-01	100 x 5 x10mm
028-01-02	100 x 5 x12mm
028-01-03	100 x 5 x15mm
028-01-04	100 x 5 x 20mm
028-01-05	150 x 6 x10mm
028-01-06	150 x 6 x12mm
028-01-07	150 x 6 x15mm
028-01-08	150 x6 x20mm
028-01-09	150 x 10 x10mm

Model Code	Size (L x W H)
028-01-10	150 x 10 x12mm
028-01-11	150 x10 x15mm
028-01-12	150 x 10 x20mm
028-01-13	150 x 15 x15mm
028-01-14	150 x15 x20mm
028-01-15	150 x15 x25mm
028-01-16	150 x15 x30mm
028-01-17	200 x15 x20mm

We also manufacture specific required sizes