

Roller Bearing 'V' Block

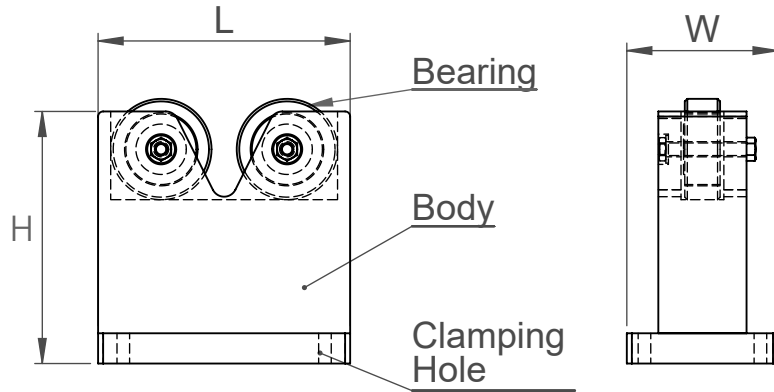
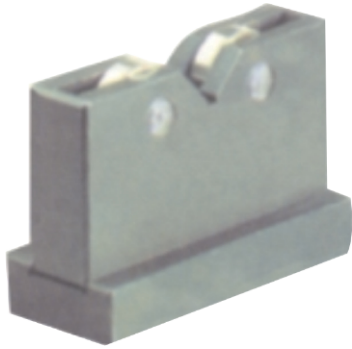

Purpose

Roller bearing 'V' block is made by alloy steel. It consists of precision ball bearings which are installed on the 'V' portion. Bearings are replaceable. It is used for inspection of concentricity of round jobs. Mainly used in Machine Shop, Assembly Shop and Tool Room.

Construction

It consists of a powerful Nd Fe B grade magnet, high permeability low carbon steel, Aluminium etc.

Advantages

- Easy for handling.
- Increasing productivity.
- No electricity is required.
- Absolutely environmentally friendly (No gases/chemicals generated)
- No maintenance is required.

Area of application

All tool room/ standard room, Machine shop etc.

Available Sizes

Model Code	Size (L x W x H)
007-01-01	150 x 60 x 100mm